

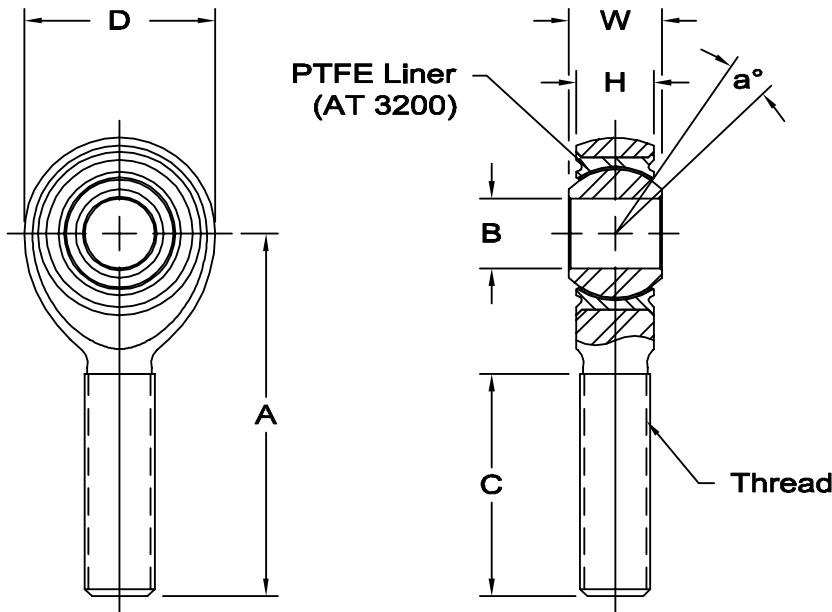

PERFORMANCE RACING SERIES

PRM-T Series Male Rod Ends - PTFE Lined

www.aurorabearing.com • Fax 630-859-0971



Body - 4340 steel, heat treated, protective coated for corrosion resistance.

Race - 17-4 PH stainless steel, heat treated

Ball - Alloy steel, heat treated, hard chrome plated. Manufacturers option: 440C stainless steel, heat treated.

PTFE liner - (AT 3200) Permanently bonded to race inside diameter. Qualified to SAE-AS81820 Type A

ROD END NO.		DIMENSIONS IN INCHES								a° Misalign. Angle	Ultimate Radial Static Load Capacity Lbs.	No Load Rotational Breakaway Torque In-Lbs.	Approx. Brg. Wt. Lbs.
Right Hand	Left Hand	B +.0000 -.0005	W +.000 -.005	H ±.005	A ±.010	D ±.010	Ball Dia. Ref.	C ±.031	Thread UNJF-3A				
PRM-5T	PRB-5T	.3125	.437	.327	1.875	.900	.593	1.187	5/16-24	14	8,330	1 - 15	.09
PRM-6T	PRB-6T	.3750	.500	.416	1.938	1.025	.687	1.187	3/8-24	8	10,946	1 - 15	.14
PRM-7T	PRB-7T	.4375	.562	.452	2.125	1.150	.781	1.281	7/16-20	10	14,049	1 - 15	.18
PRM-8T	PRB-8T	.5000	.625	.515	2.438	1.337	.875	1.468	1/2-20	9	23,310	1 - 15	.28
PRM-10T	PRB-10T	.6250	.750	.577	2.625	1.525	1.062	1.562	5/8-18	12	25,909	1 - 15	.42
PRM-12T	PRB-12T	.7500	.875	.640	2.875	1.775	1.250	1.687	3/4-16	13	34,319	1 - 15	.64